

Trace

USER MANUAL



Version 1.0.1
Revised March 31, 2023

TABLE OF CONTENTS

- OVERVIEW3
- CONFIGURATION4
 - Properties.....4
- LICENSING AND CONNECTING TO SMAART5
 - Licensing5
 - Connecting Trace to Smaart6
- CONTROLS.....10
 - Control 10
 - Connection Area.....11
 - Measurement Settings Area.....11
 - Display Area.....12
 - Operation..... 14
 - Adding Trace to a Q-SYS Design14
 - Patching Smaart to Q-SYS/Trace14
 - Operating Trace15
 - Saving Traces.....15
 - Scrub Slider16
- APPENDIX A: CONTROL PINS.....17
 - API..... 17
 - Delay..... 17
 - Display 17
 - EQ 17
 - Measurement 18
 - Signal Generator..... 18
 - Status..... 18
 - Trace..... 18
 - View..... 18
- SUPPORT.....19

OVERVIEW

Trace is a plugin for QSC's Q-SYS, designed to combine Smart data with control of named Q-SYS EQs and Delays in a single window user interface. Trace connects to a remote instance of Rational Acoustics Smart using the Smart API.

The Trace plugin requires a license key to function but can be used in demo mode for 10 minutes to evaluate the plugin. The 10-minute period can be restarted by restarting the Q-SYS™ design. Use of the plugin in demo mode for commercial purposes is prohibited.

Trace requires Smart v8.5.1.1 or later or Smart Di v2.2.0.1.

Trace is not currently compatible with Smart v9.



CONFIGURATION

The Forward Thinking Designs Trace plugin as well as the audio reference tools used with the Q-SYS™ system must be set up properly to accurately measure a sound system.

Properties

Property	Function	Choices
License Key	Enter the license key here to activate the plugin.	

Properties	
Trace Properties	
License Key	
Show Debug	No <input type="button" value="v"/>

LICENSING AND CONNECTING TO SMAART

Licensing

To license Trace, follow these steps:

1. Download the demo version of Trace from the Forward Thinking Designs website (<https://www.forwardthinkingdesigns.com/trace>).
2. Connect Trace to the API of your Smaart computer (see below).
3. Click on the About tab in the Trace plugin.

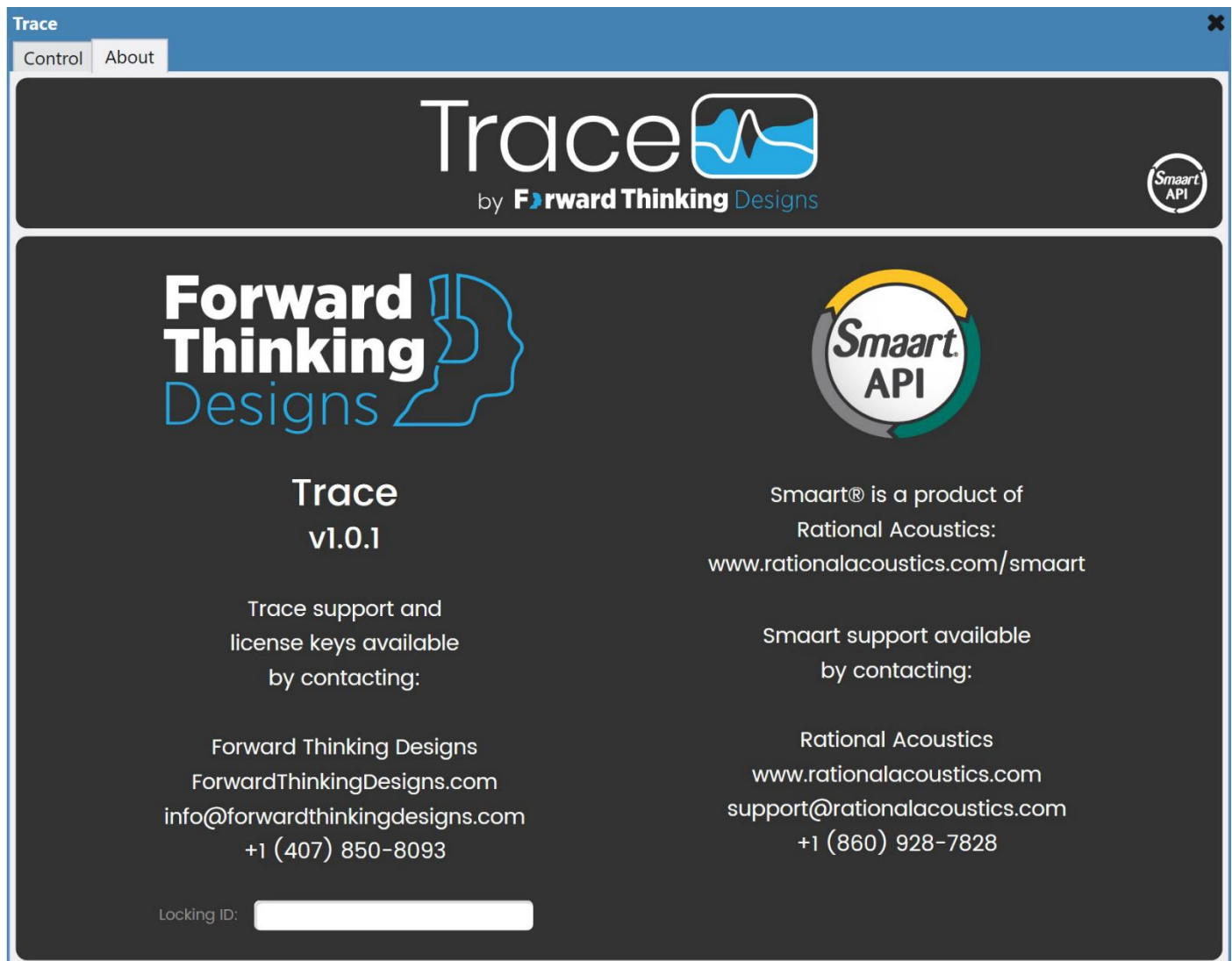

4. Copy the Locking ID.



5. Paste the Locking ID in the form that you received when you purchased Trace and send to Forward Thinking Designs (pluginsales@forwardthinkingdesigns.com).
6. Enter your License Key given to you with the purchase of the plugin in the Properties window. Without a license the plugin will only function for 10 minutes.
7. The Trace license is now linked to your computer running Smart – you can move Trace from Core to Core as long as you are using the same laptop/computer to connect and run Smart.

Connecting Trace to Smart

The Smart computer and the Q-SYS Core running Trace must be on the same network.

In Smart, click on Options -> API

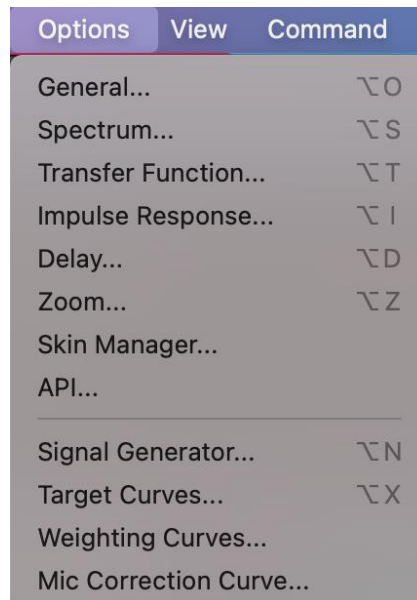

Ensure that "Enabled" is checked. The port should remain set to 26000. You can optionally add a password.

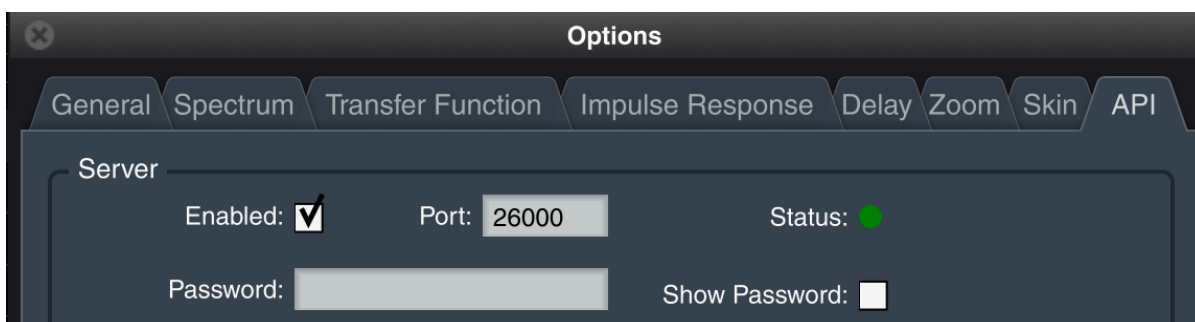

Windows Users

In Windows, the IP Address displayed is the IP address of your Smart computer. Make note of this IP address.

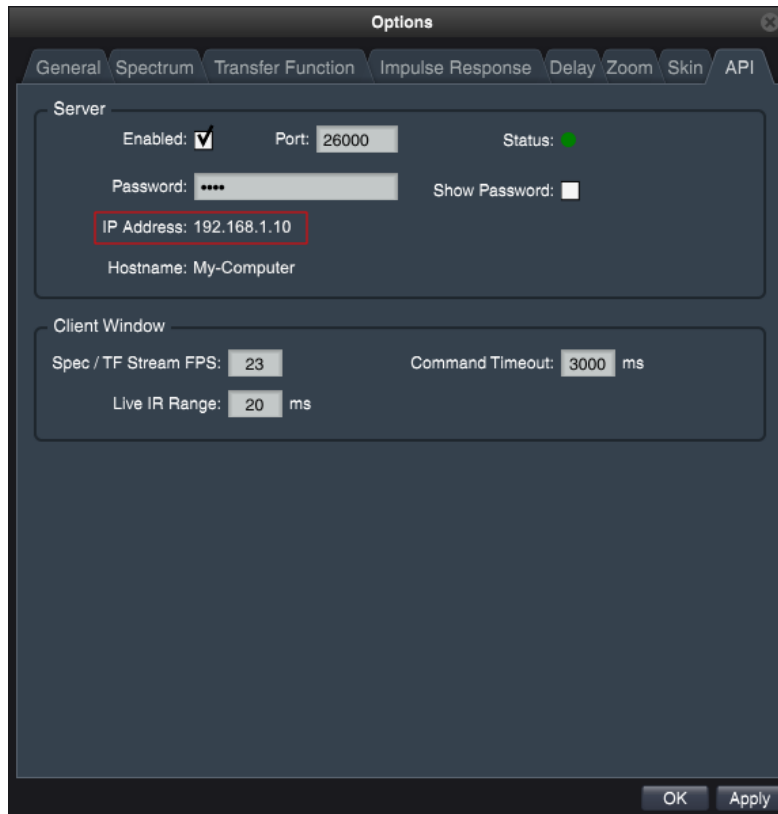

Mac OS Users

In Mac OS, the IP address displayed IS NOT correct. You will need to find your computers IP address in System Preferences -> Network. Make note of this IP address.

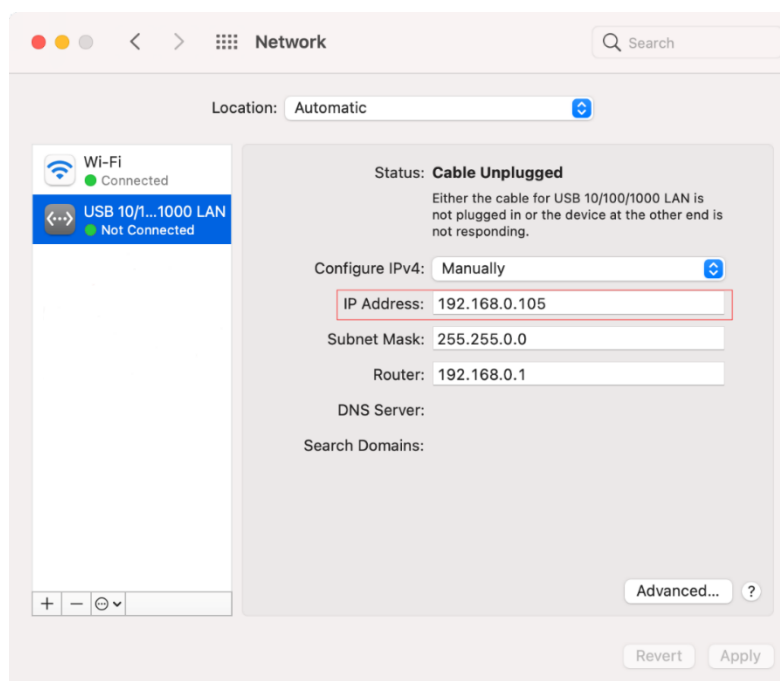
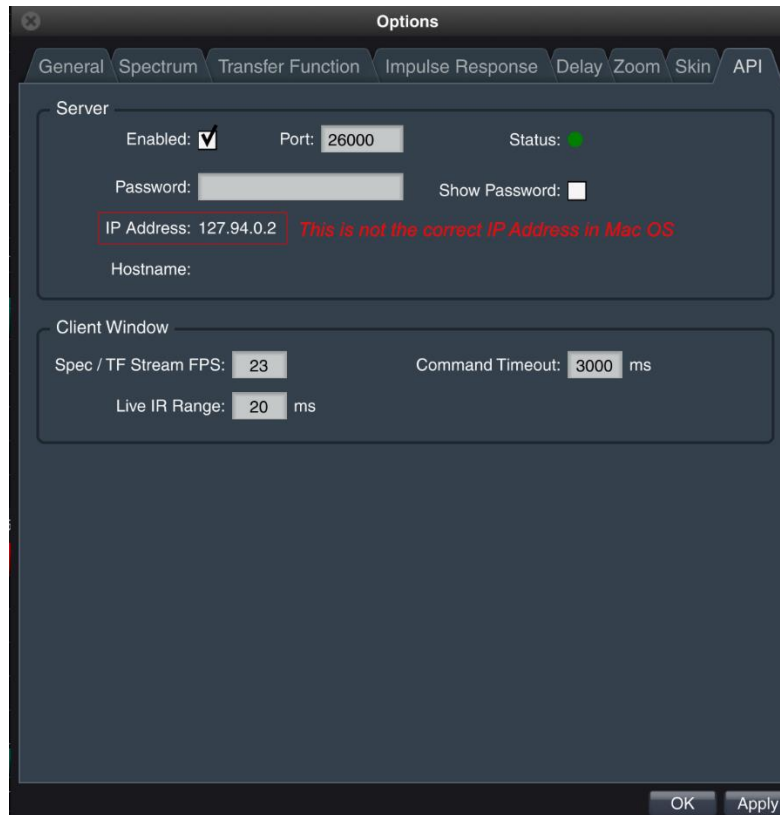

In Trace, enter the IP address of the computer running Smaart. Set the port to 26000. If you set a password in Smaart, enter the same password here.



Connect IP Address: 192.168.0.105 Port: 26000 Password: Status: OK A T I

Click Connect.

If you are properly connected, the Status bar will indicate "OK" and the green "A" will illuminate indicating a connection to the API.

CONTROLS

Control

The screenshot displays the Trace software control interface. At the top, there are tabs for 'Control' and 'About'. The main header features the 'Trace' logo and 'by Forward Thinking Designs' with a 'Smart API' icon.

Below the header, there is a 'Connect' section with fields for IP Address (172.16.1.118), Port (26000), and Password. The status is 'OK' with 'A', 'T', and 'I' buttons.

The 'Measurement' section includes:

- Measurement: Default Tab - TF: BGM Zone 1 (Enable)
- Delay: 3.25
- Tracking: Enable
- Averaging: 16 FIFO
- Phase Smooth: 1/3 Octave
- View: Magnitude, EQ, Invert EQ, Coherence, Scrub
- Global Parametric EQ Mute: (Mute icon)
- Magnitude Smooth: 1/3 Octave

The main display area shows:

- 616.0 Hz, 12.6°, 16.01 dB, 100%, 3.21 ms
- Two frequency response plots: a top plot showing a transient signal and a bottom plot showing a magnitude response.
- EQ Components: EQ 1, EQ 2, EQ 3, EQ 4. Controls include 'EQ BYPASS' and 'EQ MUTE' buttons.
- Delay Components: Delay 1, Delay 2, Delay 3, Delay 4. Controls include 'Tap 1' and '0ms' buttons.
- Signal Generator: Pink Noise (-30 dB), Enable.
- Find Delay: Find, Insert buttons. Result: 3.25, Delta: 3.23.
- Band: Band 4 (BYPASS), Type: Parametric, Freq: 4.37kHz, Gain: 0dB, Q: 1.41.

Connection Area



Connect – This button triggers the connection of Trace to the Smaart API.

IP Address – The IP address of the computer running Smaart.

Port – Should remain set to 26000.

Password – This is optional and can be set in the API menu of Smaart.

Status – Indicates the status of the Trace connection to Smaart. The “A” indicates connection to the API, “T” indicates connection to the Transfer Function, and “I” indicates connection to the Impulse Response.

Measurement Settings Area

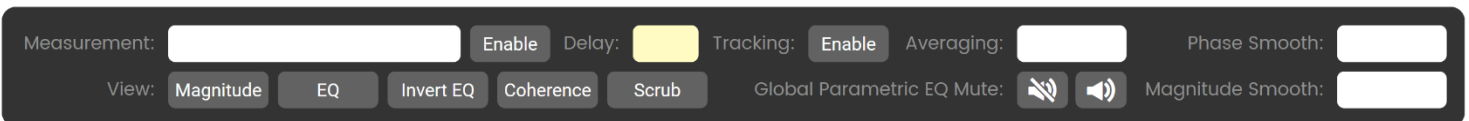

Measurement – Drop-down list displaying the available Transfer Function measurements created in Smaart.

Enable – This button enables the selected Transfer Function measurement.

Delay – Allows for manual adjustment of the Smaart Delay setting for the selected Transfer Function.

Tracking – Enables delay tracking.

Averaging – Sets the Averaging function in Smaart.

Phase Smooth – Sets the Phase Smoothing in Smaart.

View – Toggles on and off the following traces or functions in the window below:

Magnitude – Displays magnitude in the bottom window.

EQ – Displays the selected EQ curve in the bottom window.

Invert EQ – Inverts the EQ curve allowing you to trace a magnitude response.

Coherence – Displays coherence in the bottom window.

Scrub – Displays the scrub line on all three windows.

Global Parametric EQ Mute – Mutes all of the named EQs in the Q-SYS design.

Magnitude Smooth – Sets the Magnitude Smoothing in Smaart.

Display Area

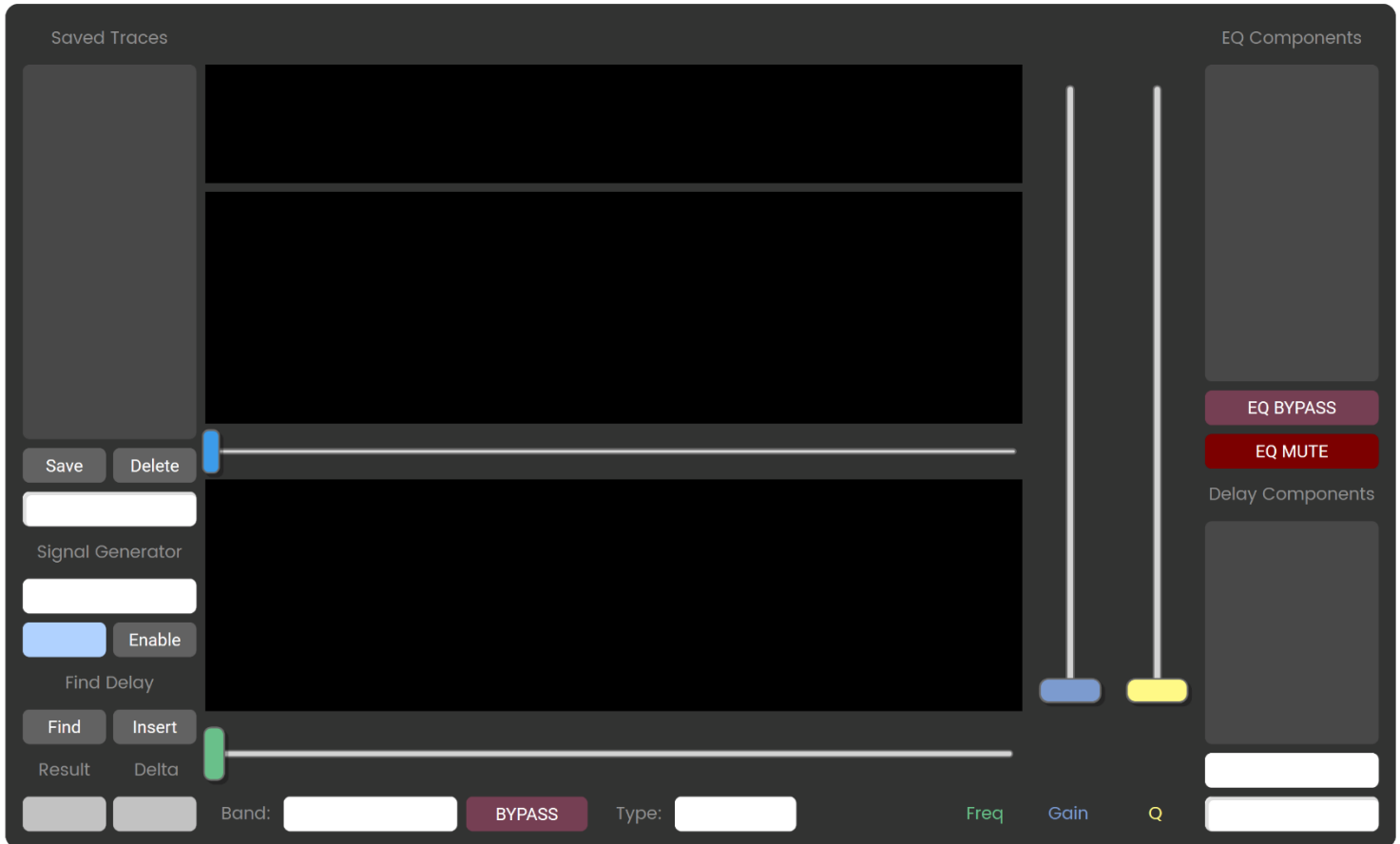

Saved Traces – Displays the traces saved in Trace. Note: traces are also stored in Smart. Trace can only recall traces stored in Trace. Deleting traces in Trace will not delete them in Smart.

Scrub Data – Displays the Frequency, Phase, Magnitude, Coherence, and Delay based on the position of the Scrub slider.

EQ Components – Displays the list of all Named Parametric EQs in the Q-SYS design.

EQ Bypass – Bypasses the selected EQ.

EQ Mute – Mutes the selected EQ.

Delay Components – Displays the list of all Named Delays in the Q-SYS design.

Tap X – Drop-down list to select the desired Tap for the selected Delay.

Delay Time – Displays the current delay time for the selected Delay and Tap.

Signal Generator – Provides controls for the Smart Signal Generator.

Pink Noise – Drop-down list allows for selection of various Smart noise sources.

Level – Adjusts the level of the selected noise source. Adjustments may be made via direct numeric input or click-drag.

Enable – Toggles to enable or disable the Smart Signal Generator.

Find Delay – Provides controls for the Smart Delay Finder.

Find – Finds the delay of the Smart Impulse Response.

Insert – Inserts the found delay into the Smart Transfer Function.

Result – Displays the delay time.

Delta – Displays the difference between the most recent found delay and the previous delay time.

EQ Adjustments – Provides controls for adjusting the selected Q-SYS EQ.

Band – Selects the band of selected EQ.

Bypass – Bypasses the selected EQ band.

Type – Sets the type: Parametric, High-Shelf, Low-Shelf.

Sliders – Adjust Frequency, Gain and Q. Numeric entry is also allowed.

Operation

Adding Trace to a Q-SYS Design

Adding Trace to a Q-SYS design is as simple as dropping the plugin anywhere into the design. Trace automatically detects Named Parametric EQs and Named Delays and adds them to the EQ Components and Delay Components areas.

Note: Trace cannot discover/control EQs in Channel Groups.

Patching Smart to Q-SYS/Trace

Your Smart computer can be patched to Q-SYS/Trace in several possible ways. Smart can be patched via Dante, via analog, or using the Core itself as the soundcard. One possible method, using Dante, is pictured below.

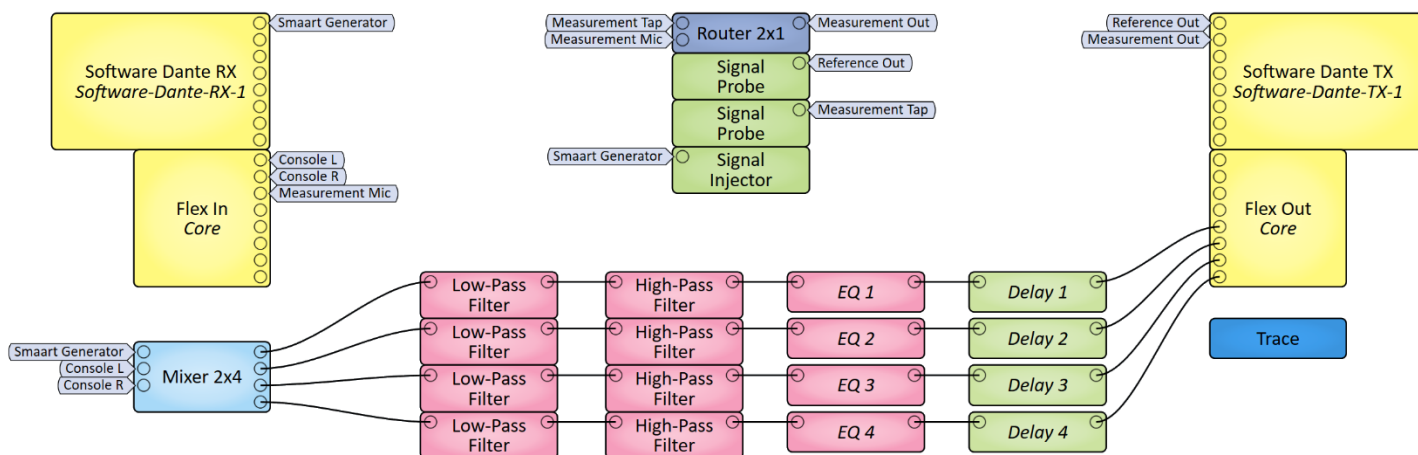

Operating Trace

Once connected, Trace operates almost identically to Smaart. Select the Measurement from the drop-down list, click Enable, and you are ready to start making measurements.

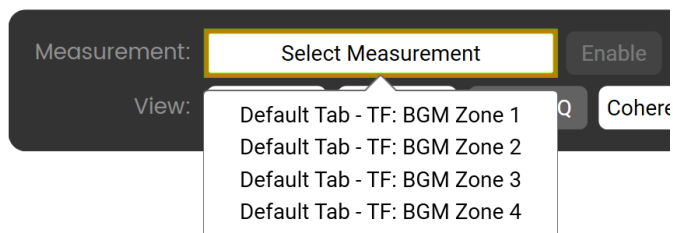

Click on an EQ in the EQ Components list to select the EQ you want to adjust. The Band drop-down list selects the EQ band and the sliders or numeric entries can be used to make adjustments. The Type drop-down list selects between Parametric, High-Shelf, and Low-Shelf filters.

Click on a delay in the Delay Components list and select the appropriate tap from the Tap drop-down list. Enter a value in the window to apply the delay time.

Saving Traces

Type a name for your trace in the box and click Save. The trace will be added to the list of Saved Traces. Clicking on a trace in the list displays it in the Magnitude window. Only one Saved Trace can be displayed at a time. Traces saved in Trace are also saved in Smaart. Deleting a Saved Trace in trace will not delete it in Smaart.



Scrub Slider

Since Trace does not allow for Peak Tracking, we have included a Scrub Slider to help identify exact values of any given point in the data windows. The Scrub Slider works across all three windows simultaneously and displays the numeric values at the top of the measurement area.

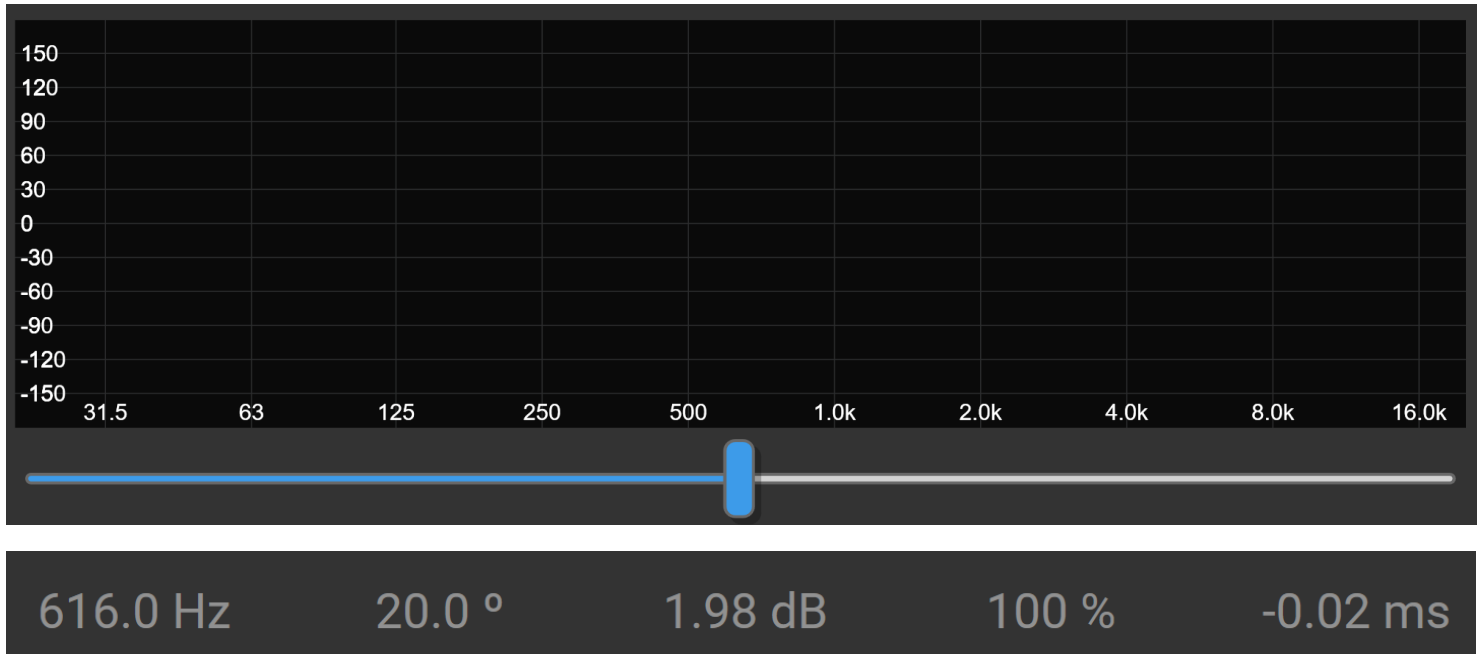

APPENDIX A: CONTROL PINS

API

Pin Name	Control Type	Value Range	Pin Direction
Connect	Button - Toggle	False / True	Input / Output
IP Address	Text	Valid IPv4 Address	Input / Output
Password	Text	User Defined (optional)	Input / Output
Port	Knob - Integer	1 – 65535	Input / Output

Delay

Pin Name	Control Type	Value Range	Pin Direction
Delay	Text		Input / Output
Select	Text		Input / Output
Tap	Text		Input / Output

Display

Pin Name	Control Type	Value Range	Pin Direction
Coherence	Text		Output
Frequency	Text		Output
Impulse	Text		Output
Magnitude	Text		Output
Phase	Text		Output
Scrub	Knob - Integer	20 – 20000 (Default=628)	Output

EQ

Pin Name	Control Type	Value Range	Pin Direction
All Mute	Button - Trigger		Input / Output
All Unmute	Button - Trigger		Input / Output
Band Bypass	Button - Toggle	False / True	Input / Output
Band Select	Text		Input / Output
Band Type	Text		Input / Output
Bypass	Button - Toggle	False / True	Input / Output
Frequency	Knob – Hz	20 – 20000 (Default=628)	Input / Output
Gain	Knob – dB	-100 – 20 (Default=0)	Input / Output
Mute	Button - Toggle	False / True	Input / Output
Q	Knob - Float	0.404 – 144 (Default=0)	Input / Output
Select	Text		Input / Output
User Gain	Knob - dB	-100 – 20 (Default=0)	Input / Output
User Q	Knob - Float	0 – 1 (Default=0)	Input / Output

Measurement

Pin Name	Control Type	Value Range	Pin Direction
Averaging	Text	(Default=1 Second)	Input / Output
Delay	Knob – Float	-1000 – 1000 (Default=0)	Input / Output
Delay Delta	Text		Output
Delay Result	Text		Output
Enable	Button – Toggle	False / True	Input / Output
Find Delay	Button – Trigger	False / True	Input / Output
Insert Delay	Button – Trigger		Input / Output
Magnitude Smoothing	Text	(Default=1/3 Octave)	Input / Output
Phase Smoothing	Text	(Default=1/3 Octave)	Input / Output
Select	Text		Input / Output
Tracking	Button – Toggle	False / True	Input / Output

Signal Generator

Pin Name	Control Type	Value Range	Pin Direction
Enable	Button – Toggle	False / True	Input / Output
Gain	Knob - Integer	-99 – 0 (Default=-40)	Input / Output
Mode	Text		Input / Output

Status

Pin Name	Control Type	Value Range	Pin Direction
API	Indicator - LED	Off / On	Output
Impulse	Indicator - LED	Off / On	Output
Status	Indicator – Status	Off / On	Output
Transfer	Indicator - LED	Off / On	Output

Trace

Pin Name	Control Type	Value Range	Pin Direction
Delete	Button – Trigger		Input / Output
Name	Text		Input / Output
Save	Button – Trigger		Input / Output
Select	Text		Input / Output

View

Pin Name	Control Type	Value Range	Pin Direction
Coherence	Button – Toggle	False / True (Default=True)	Input / Output
EQ	Button – Toggle	False / True (Default=True)	Input / Output
Invert EQ	Button – Toggle	False / True	Input / Output
Magnitude	Button – Toggle	False / True (Default=True)	Input / Output
Scrub	Button – Toggle	False / True (Default=True)	Input / Output

SUPPORT

For plugin support and feedback please contact us at:

ForwardThinkingDesigns.com

support@forwardthinkingdesigns.com

+1 407-850-8093

+1 800-4840-FTD

QSC® and Q-SYS™ are a trademark or registered trademark of QSC, LLC in the U.S. Patent and Trademark Office and other countries.
Smaart® is a registered trademark of Rational Acoustics, LLC in the U.S. Patent and Trademark Office and other countries.